

FINAL DEGREE THESIS

Electrical Characterization of a Textile Sensor for Moisture Detection

By

Arun Swaminathan

Muhammad Babar Khan



HÖGSKOLAN I BORÅS

INSTITUTIONEN INGENJÖRSHÖGSKOLAN

FINAL DEGREE THESIS 15 ECTS, 2010-11 SWEDEN

THESIS N° 1/2011, BIOMEDICAL ENGINEERING

Electrical Characterization of Textile Sensor for Moisture Detection

Arun Swaminathan

arunshines@gmail.com

Muhammad Babar Khan

Khanbabar3@ymail.com

Master thesis

Subject Category: Medical Technology, Electrical Engineering

University of Borås

School of Engineering

SE- 501 90 BORÅS

Phone number: +46 33 435 4640

Examiner: Fernando Seoane Martínez

Supervisor: Fernando Seoane Martínez

Keywords: Electrical Impedance, Textile sensors, MATLAB

Dedicated

To Beloved Mother, Father

Abstract

Electrical impedance is the frequency domain ratio of the voltage to the current. Electrical impedance extends the concept of resistance to AC circuits, describing not only the relative amplitudes of the voltage and current, but also the relative phases. Many new generation impedance measuring instruments measure the real and imaginary part of the impedance vector.

Textile sensors are becoming an emerging field in industry. The possibilities that this technology holds seem almost limitless. Currently, textiles are being developed for many applications and markets, including biomedical sensing, wearable computing, large area sensors and large area actuating devices.

A novel concept for a textile sensor for detection of moisture surroundings The sensor has been theoretically analysis. The results of the developed sensor shows less resistance drop characteristics against sweat.

Acknowledgements

Thanks to Almighty

We want to express our gratitude to all the people who have given their heart whelming full support in making this project a magnificent experience.

We are grateful to all my friends being the surrogate family during the year we stayed in Sweden and for their continued love and support thereafter. We would like to dedicate our entire work to our family who has been our constant support in all our works in giving us not just financial, but morally and spiritually. They have lost a lot due to my research abroad. Without their encouragement and understanding it would have been impossible for me to finish this work. We love you mummy, daddy.

We would like to express our deep and sincere gratitude to my supervisor and Examiner, Dr. Fernando Seoane Martinez, for his help and support in this whole program. His wide knowledge and his logical way of thinking have been of great value for me. His understanding, encouraging and personal guidance have provided a good basis for the present thesis. He has been our major inspiration since we started this program. Working under his guidance we got to learn lots of things which are priceless.

Regards

Arun Swaminathan

Muhammad Babar Khan

TABLE OF CONTENTS

CHAPTER 1. Introduction	9
1.1. Introduction	9
1.2. Motivation	9
1.3. Goal	9
1.4. Work done	9
1.5. Structure of the Thesis Report	9
CHAPTER 2. Textile Sensor	10
2.1. Introduction	10
2.2. Types and Applications of Textile sensors	11
2.2.1. Stretch Sensors	11
2.2.2. Temperature Sensors	11
2.2.3. Pressure Sensors.....	11
2.2.4. Textile Electrodes	11
2.2.5. Chemical Sensors	13
2.2.6. Moisture Sensors	13
CHAPTER 3. Impedance	14
3.1. Introduction	14
3.2. Measuring Impedance	14
3.3. Multi-meter:	15
3.4. Circuit Transformation	16
3.4.1. Series Connection.....	16
3.4.2. Parallel Connection.....	16
3.4.3. Y to Δ Transformation.....	17
CHAPTER 4. Textile Enabled Moisture Sensor Concept	18
4.1. Introduction	18
4.2. Analysis Of Sensor Concept	19
4.3. Theoretical Calculation	20
4.3.1. Short Circuiting Different Threads.....	25
4.4. Electrical Validation of Sensor Concept	26
4.5. Characterization of the Moist Sensor	27
4.5.1. Sensor Dynamic Characterization.....	27

CHAPTER 5. Results 28
5.1. Resistance Characteristics Of Textile Sensor..... 28
5.2. Electrical Validation Of Textile Sensor..... 29
5.3. Resistance Characteristics Of Sweat Sensor 29
CHAPTER 6. Discussion 33
CHAPTER 7. Conclusion and Future work 34
7.1. Conclusion 34
7.2. Future Work 34
References 35

List of Acronyms

EI- Electrical Impedance

Z-Impedance

R-Resistance

T-Time

1.1. INTRODUCTION

Electrically conductive materials can be used as textile yarn for knitting and weaving fabrics to enable functional garments. The use of such conductive materials provides textile fabrics with electrical properties and through proper monitoring several sensing application can be enable.

1.2. MOTIVATION

There are several applications that require the detection of a change in the moisture of the surrounding environment. This type of moisture sensors can be use for the detection of leakage in pipes or sweat production. The use of textile material for the implementation of such moisture sensors would allow the production of disposable and easy to handle sensors.

1.3. GOAL

The main goal of this project is to test a novel concept and characterize the nominal electrical values for a textile sensor for prompt detection of Humidity changes.

1.4. WORK DONE

The analysis of the concept behind the sensing process has been study and tested on a sample sensor using saline water. The nominal values and the expected changes on the impedance of the sensor have calculated and experimental test have done for validation. The nominal values for the sensor have been also calculated and measured.

1.5. STRUCTURE OF THE THESIS REPORT

This Report is organized in 7 chapters and References. Chapter 1 gives a brief introduction to the work done. An introduction to textile sensor and its applications is explained in chapter 2 while chapter 3 covers the introduction to electrical Impedance and the measuring instruments used for characterization and analysis. Chapter 4 introduces the theoretical analysis of sensor concept. The results of the theoretical and electrical validation of the textile sensor are presented in chapter 5 and work discussion is chapter 6. Finally conclusions and proposed future work are outlined in chapter 7. References are listed at the end of the thesis report.

2.1. INTRODUCTION

Textiles are inherent microstructures with good properties like they are flexible and much more mechanically stable than foils. The term ‘textronics’ refers to interdisciplinary approaches in the processes of producing and designing textile materials. It is a synergic connection of textile industry, electronics and computer science with elements of automatics and metrology knowledge^[1]. Textile sensors are becoming an emerging field in industry. The possibilities that this technology holds seem almost limitless. Currently, textiles are being developed for many applications and markets, including biomedical sensing, wearable computing, large area sensors and large area actuating devices^[2]. Additionally, clothing provides a large surface which can be used for sensing. The concept of textiles are developed and readily applied to many existing products. Textile sensors are becoming rapidly interconnected by technology, the addition of textile sensor components to everyday products, as well as specifically targeted designs will provide the ability to enhance product performance and provide new and unique services to customers.

Electrical conductivity over fabrics is one of the challenges in electro-textiles, different materials and ways are available: carbon black, some metals and recently conductive polymers are currently engineered in the market as fibers, yarns, pastes, etc^[3] that could be applied to fabrics by different standard techniques: weaving, knitting, coating, laminating, printing, etc.^[4]. Some of these techniques are not versatile to achieve stable and homogeneous conductive tracks or surfaces with a predefined geometry. Mainly some attempts has been tried to trace conductive tracks with high conductivity by weaving monofilament conductive metal yarns^[5] and recently other attempts involved techniques used in printed flexible electronics over fabrics by using conductive inks or pastes^[6].

2.2. TYPES AND APPLICATIONS OF TEXTILE SENSORS

2.2.1. STRETCH SENSORS

Stretch sensors have unique characteristics of changing resistance when stretched. They are made up of elastic fibers, which make the sensor very flexible. The resistance gradually increases when the sensor material is stretched. The sensor material has a nominal resistance of 1000 ohms per linear inch. These sensors are used to measure breathing movement of lungs and joints movements^[7].

2.2.2. TEMPERATURE SENSORS

Temperature sensor measures the hotness of any material that might be textile or body. The sensors used in textile are made up of polymers that changes resistivity with temperature. The sensor is integrated into the fabric by weaving process. It has got many applications and the most interesting application is in measuring infant temperature^[8].

2.2.3. PRESSURE SENSORS

Pressure sensors measure the pressure information from the surface of fabrics under stress by means of capacitive sensing. The fabrics with these types of sensors composed of passive array of capacitors, whose capacitance depends on the exerted pressure on the textile surface^[9].

2.2.4. TEXTILE ELECTRODES

Textile electrodes are made of different types of conductive yarns and polymers^[10]. Electrodes can sense even very small voltages of different body parts e.g. heart. Textile electrodes are now becoming a popular choice because of their comfort of use and weave in cloths. Textile electrodes that can also be embedded into sports clothing to measure averaged rectified EMG have been developed for an easy use in the field tests and in clinical settings^[11]. In electronic textiles miniature electrical components are integrated into the fabrics in order to monitor different biological measurands, body movements and postures. Textile electrodes are being used in measuring ECG, EMG as well as electrical impedance produced by different body parts^[12].

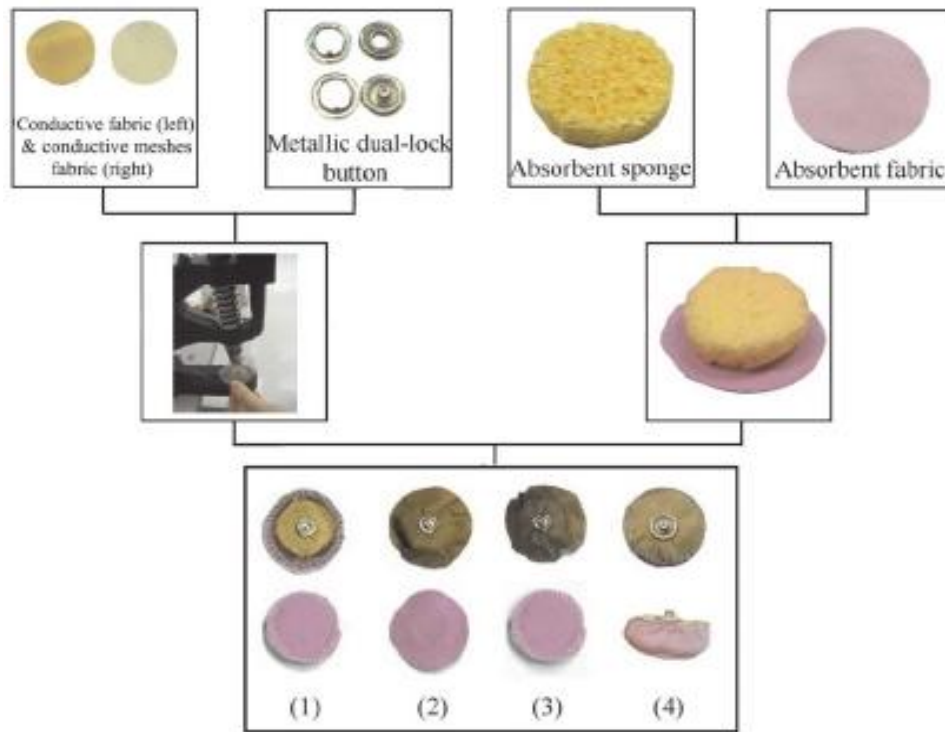

Figure 2.1: Materials used for textile electrodes

NuMetrex Heart Sensing Sports Bra is a garment that incorporates textile-sensing technology. Electronic sensing fibers are knitted directly into the fabric, where they pick up the wearer's heartbeat and radio it to a watch via a tiny transmitter in the front of the bra ^[13].



Figure 2.2: NuMetrex Heart Sensing Sports Bra

2.2.5. CHEMICAL SENSORS

These are yet another component used in smart textiles. Chemical sensors are integrated directly on the inside elastic waistband of underwear, where they measure the biomarkers in sweat. These sensors give useful information about the wearer's health ^[14] ^[15].

2.2.6. MOISTURE SENSORS

Moisture sensors are based on interdigital weave. These sensors measure the change in resistance brought in by the amount of water present, such as sweat. In this sensor the resistive signal is proportional to the actual moisture. These sensors are made up of conductive polymers.

This is the type of sensor that is going to be studied in this report. The change in resistance is found when the positive and negative pole get in contact by water in between ^[16]. This is been explained in detail in the following chapters.

3.1. INTRODUCTION

Electrical impedance (EI), or simply impedance, is a measure of opposition to alternating current (AC). Electrical impedance extends the concept of resistance to AC circuits, describing not only the relative amplitudes of the voltage and current, but also the relative phases. When the circuit is driven with direct current (DC) there is no distinction between impedance and resistance; the latter can be thought of as impedance with zero phase angles. Impedance is defined as the frequency domain ratio of the voltage to the current. In other words, it is the voltage–current ratio for a single complex exponential at a particular frequency. In general, impedance will be a complex number, with the same units as resistance, for which the SI unit is the ohm (Ω).^[17]

3.2. MEASURING IMPEDANCE

In order to measure the impedance at least two values should be measure as impedance is a complex quantity. Many new generation impedance measuring instruments measure the real and imaginary part of the impedance vector and then switch them into preferred parameters such as $R, G, X, B, \theta, |Z|$ and $|Y|$. It is merely necessary to connect the unknown circuit or component or material to the instrument. Resistance R is the real part of impedance; any device gives purely resistive impedance which exhibits zero phase shifts between the voltage and current.

Impedance is the opposition of a circuit to the flow of electric current. Ohm's law states that the current I flowing in a circuit is proportional to the applied potential difference V . The constant of proportionality is defined as the resistance R . Hence the equation, $V=IR$ holds. If V and I are measured in volts and amperes, R is measured in ohms. On Microscopic level, resistance is the impedance to the flow of charge carriers offered by the material. It is measure of the opposition that an electrical circuit presents to the flow in passage of a current when a voltage is applied^[18].

An ohm as a resistance between two points of a conductor when a constant potential difference of 1 volt, applied to these points, produces in the conductor a current of 1 ampere. In many cases the resistance of a conductor in ohms is approximately constant within a range of voltages, temperature etc.; one speaks of linear resistors. In other cases resistance varies (e.g., thermistors). In alternating current circuits, electrical impedance is also measured in ohms^[19].

3.3. MULTI-METER:

A Multi-meter also known as a Volt/ohm meter or VOM is an electronic measuring instrument that combines many measurement functions in a single unit. A typical multi-meter can include features to measure voltage, current and resistance. Multi-meters may use analog or digital circuits—Analog multi-meters and Digital multi-meters. Analog instruments are based on a micro-ammeter whose pointer moves over a scale calibration for all the different measurements that can be made to digital instruments usually by display digits, but may display a bar of a length



Figure 3.1: Multimeter

proportional to the quantity measured ^[20].

An object of uniform cross section has a resistance proportional to its resistivity and length and inversely proportional to its cross-sectional area.

The SI unit of electrical resistance is given the ohm (Ω). Resistance's reciprocal quantity is electrical conductance measured in Siemens.

The resistance of an object is the ratio of voltage to current:

$$R = \frac{V}{I}$$

For a range of materials and conditions the electrical resistance R is constant for a given temperature and it is not dependent on the amount of current through or the voltage across the object. Such materials are called Ohmic materials. For objects made of Ohmic materials the definition of the resistance, with R being a constant for that resistor, is known as Ohm's law ^[21].

3.4. CIRCUIT TRANSFORMATION

3.4.1. SERIES CONNECTION

Series connection is a connection in which if there is a path from a terminal of one of the elements to a terminal of the other element that does not branch off at any point then it is said that the two terminal elements are in series. If resistors are arranged in a chain, so the current has only one path to take then the current is same through each resistor. The total resistance of the circuit is found by simply adding up the resistance values of the individual resistors,

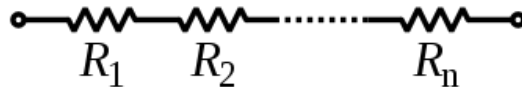

Figure 3.2: Resistors in Series

Equivalent resistance of resistors in series: $R_{\text{Total}} = R_1 + R_2 + \dots + R_n$

3.4.2. PARALLEL CONNECTION

Parallel Connection is a connection in which a two terminal element is in parallel with another two terminal element if they have common nodes for both of their terminals. If resistors are arranged with their heads connected together, and their tails connected together, so that the current in a parallel circuit breaks up, with some flowing along each parallel branch and re-combining when the branches meet again. The voltage across each resistor in parallel is the same. The total resistance of a set of resistors in parallel is found by adding up the reciprocals of the resistance values, and then taking the reciprocal of the total,

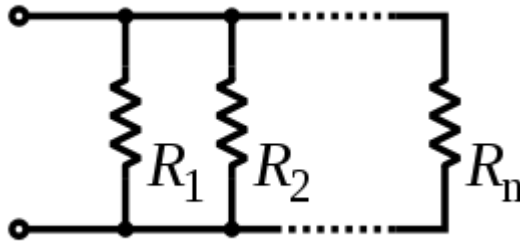

Figure 3.3: Resistors in Parallel

Equivalent resistance of resistors in parallel: $1 / R = 1 / R_1 + 1 / R_2 + \dots + 1 / R_n$

3.4.3. Y TO Δ TRANSFORMATION

Y-Δ transform is a mathematical technique to simplify the analysis of an electrical network. The transformation is done used to establish equivalence for networks with three terminals. Where three elements terminate at a common node and none are sources, the node is eliminated by transforming the impedances. For equivalence, the impedance between any pair of terminals must be the same for both networks. The equations given here are valid for complex as well as real impedances. This transformation is done by the formula

$$R_{\Delta} = R_P / R_{\text{opposite}}$$

Where $R_P = R_1R_2 + R_2R_3 + R_3R_1$ is the sum of the products of all pairs of impedances in the Y circuit and R_{opposite} is the impedance of the node in the Y circuit which is opposite the edge with R_{Δ} . The formulas for the individual edges are thus

$$R_a = R_1R_2 + R_2R_3 + R_3R_1 / R_2$$

$$R_b = R_1R_2 + R_2R_3 + R_3R_1 / R_3$$

$$R_c = R_1R_2 + R_2R_3 + R_3R_1 / R_1$$

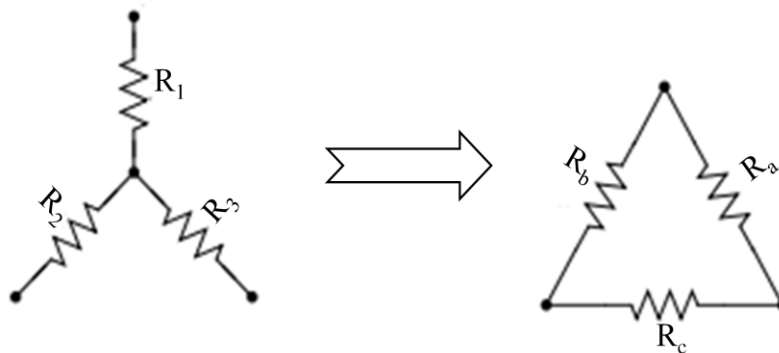

If the values are used in this formula the transformation is given as Fig.3.3

4.1. INTRODUCTION

A woven fabric containing conductive fibers of creating a specific pattern is studied. The fabric made off conductive fabrics and cotton is used to confection a sensor. The sensor concept is analyzed and experimental measurements are taken to test the concept. The core of the sensor is made of textile fabric with conductive fabric forming a pattern, as illustrated in Fig.4.1.

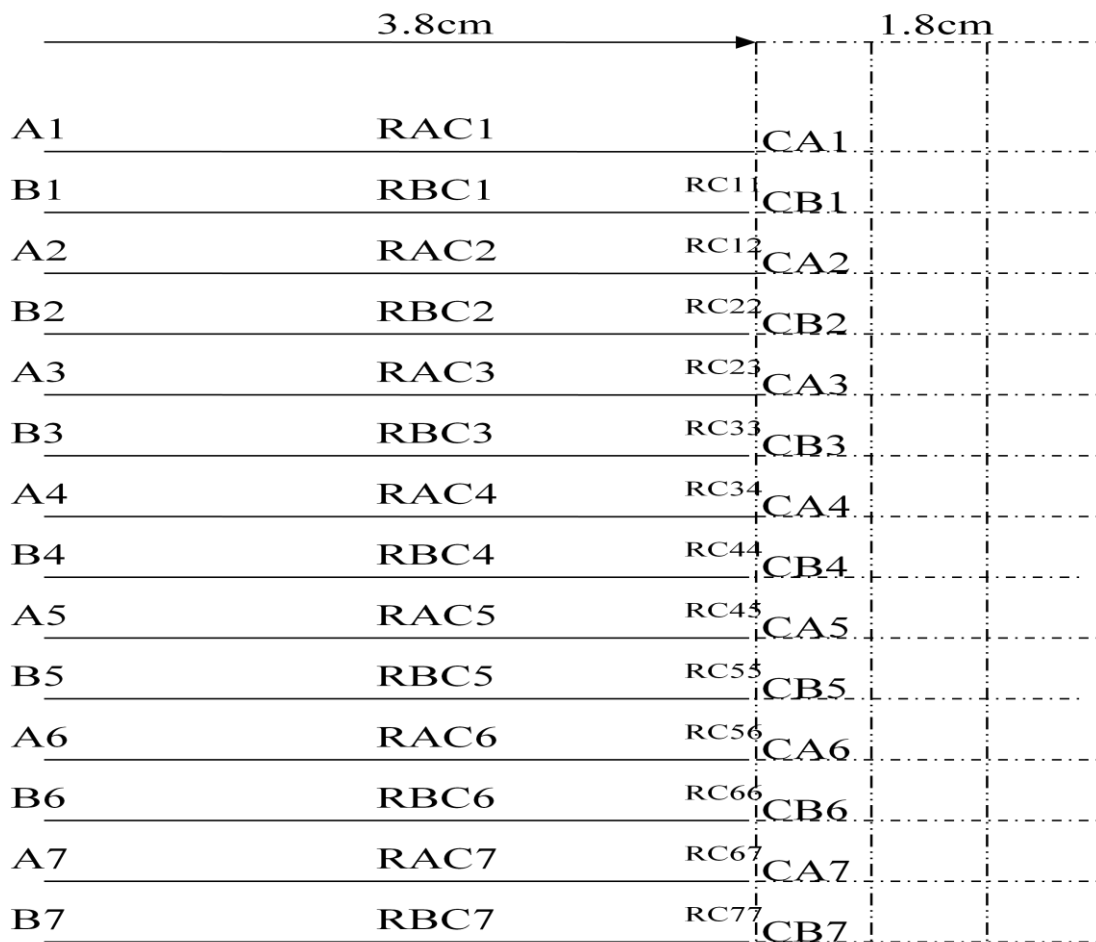

Figure 4.1: Pattern, Implemented on the Textile sensor

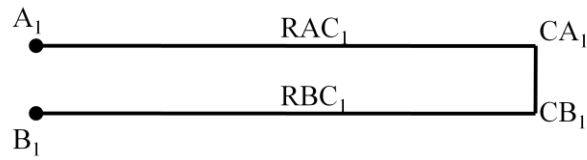

Figure 4.2: Measure from A₁ to B₁

4.2. ANALYSIS OF SENSOR CONCEPT

The conductivity of the fabric is found from A₁ to B₁ as shown in the Fig.4.2.

The sensor has two sides, one with two connectors and the other with Y interconnections, All threads are conductive and connected to either A or B connections in one side and to Y connection on the other side. This produces the following electrical equivalent as shown in Fig.4.3.

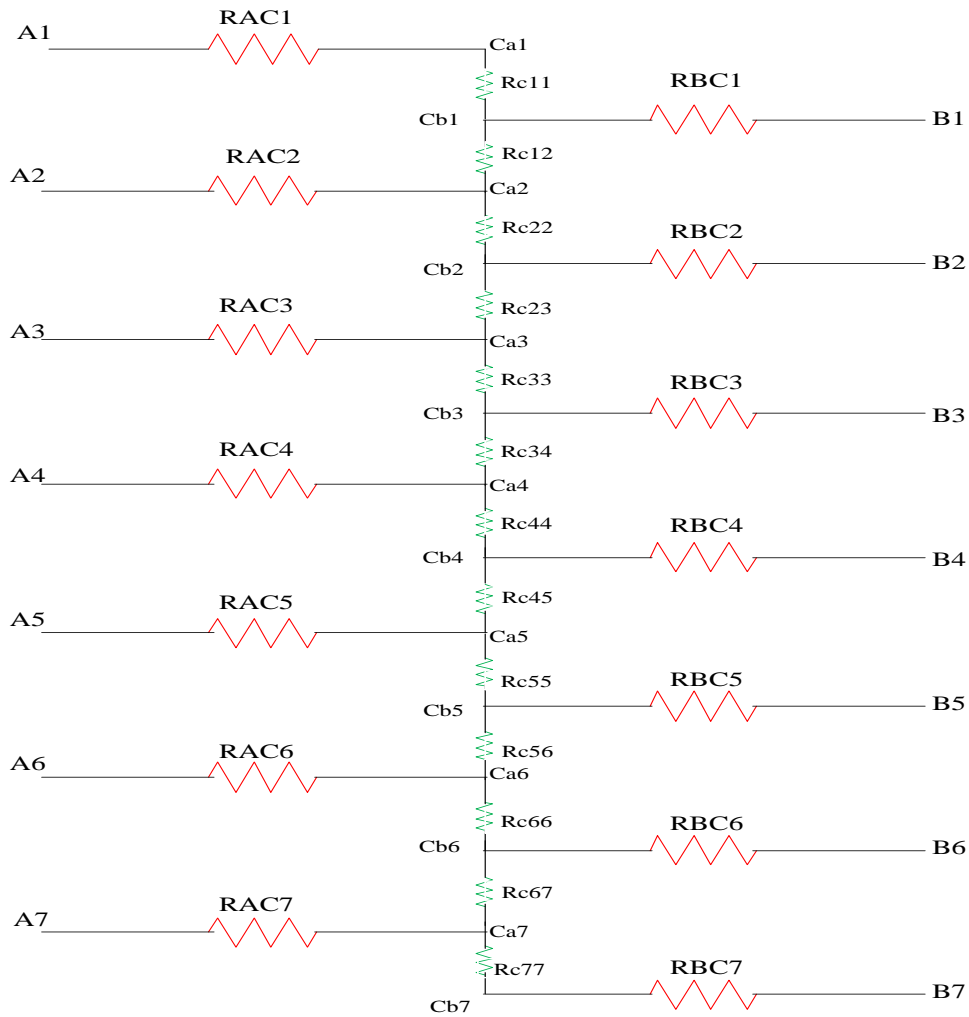

Figure 4.3: Electrical Equivalent

The impedance of the sensor is measured between terminals A and B. When a drop of sweat is applied in the sensor, it would create a conductive circuit between threads modifying the impedance observed between A& B. This falls down the impedance forming a hole that make short circuit and the results are discussed in Chapter 5.1.

4.3. THEORETICAL CALCULATION

To find total impedance for the electrical equivalent circuit, the circuit must be reduced. In the first step, the points B7, Cb7, Ca7, A7, Cb6, B6 and Ca6 are taken into consideration. Resistors RBC7 and Rc77 are in series, so as discussed in Chapter 3.3.1, the both resistors can be summed up and now the circuit looks as shown in the Fig.4.4.

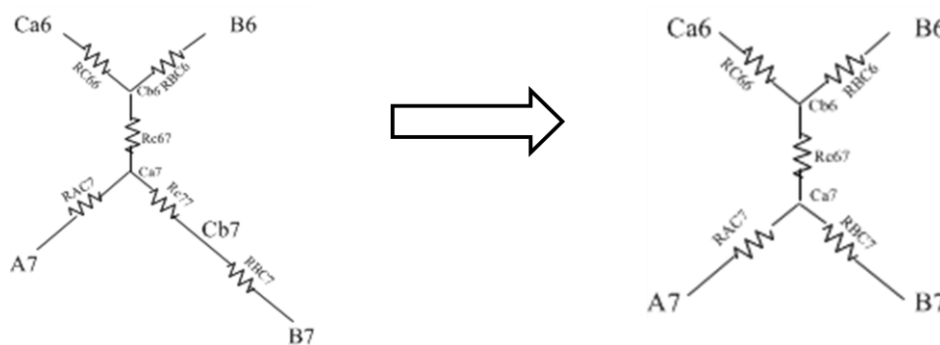

Figure 4.4: Summed up series Resistors

In the second step Cb6, Ca7, B7 and A7 looks like Y network, this can be converted by Y- Δ transformation as discussed earlier in chapter 3.3.3 and now the circuit looks as shown in the Fig.4.5.

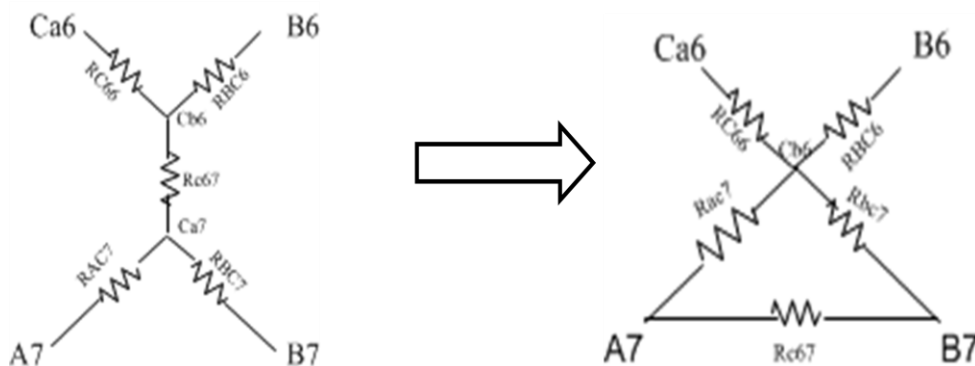

Figure 4.5: Converting Y to Δ circuit

Since B6 and B7 have same conductivity, the resistors RBC6 and Rbc7 are in parallel, so as discussed in Chapter 3.3.2 the sum of the reciprocal of both resistors is equal to the reciprocal of the total and thus the circuit is reduced as shown in Fig.4.6

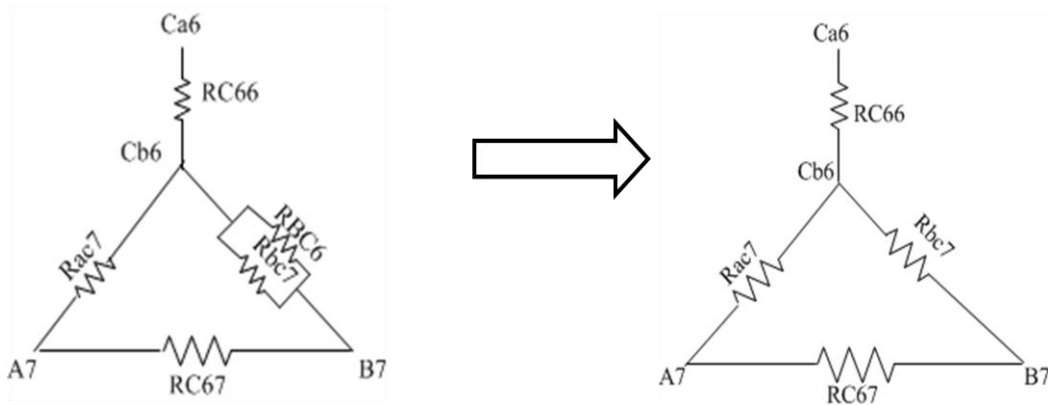

Figure 4.6: Converted after taking the parallel resistors

Now the resistor RC67 is kept as such and the remaining circuit looks like a Y shaped circuit and this can be again converted to Δ circuit. Here A6 and A7 have same conductivity and resistor RAC6 and Rbc7 are taken in parallel.

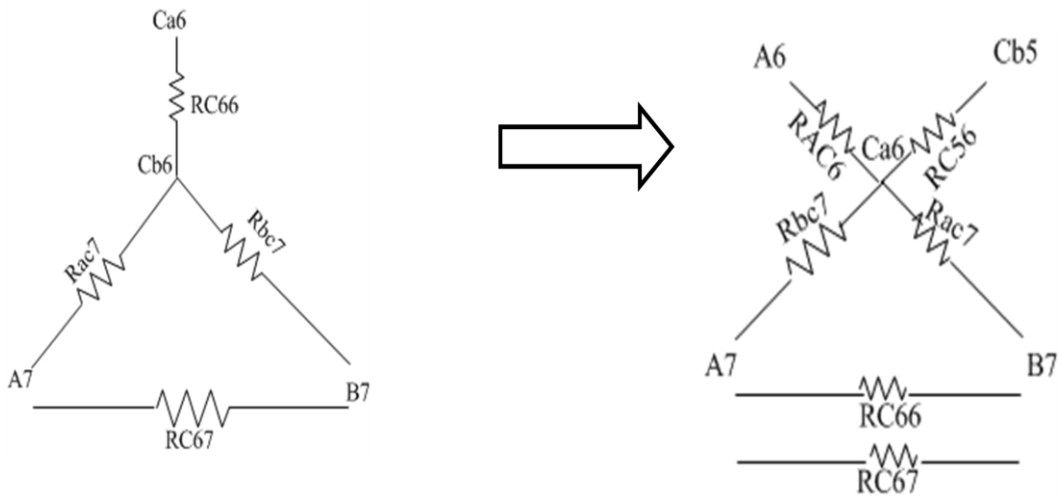

Figure 4.7: Converting Y to Δ circuit

Thus the steps are repeated and the circuit is reduced and finally looks like Fig.4.8

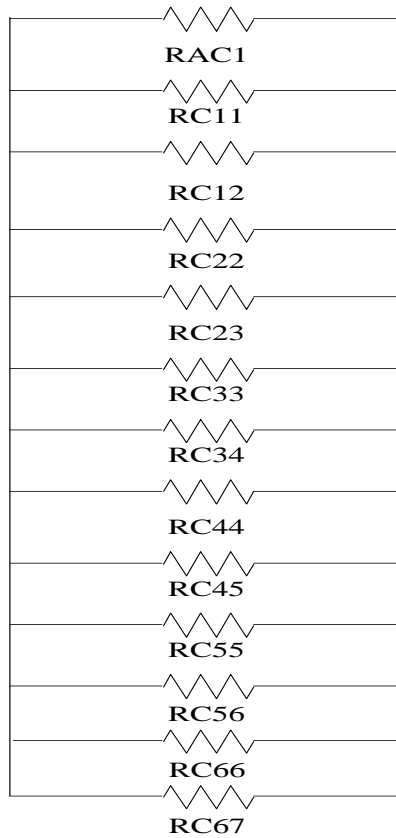

Figure 4.8: Converting Y to Δ circuit

The parallel of the resulting connection is calculated and the total impedance is found.

This theoretical calculation can be simplified and done easily using MATLAB. The code 4.1 gives the total impedance value when the resistance obtained is inputted to the program.

```
%Finding Total Resistance
%Input A side Resistance values
for i = 1:14
    RA(i) = input('RA..');
end
%Input B side Resistance values
for i=2:14
    RB(i) = input('RB..');
end
```

```

%Adding the series values
RA(14) = RB(14)+RA(14);
%y-Δ Transformation
RP1=RB(13)*RA(13)+RA(13)*RA(14)+RB(13)*RA(14);
Rb(13)=RP1/RB(13);
Ra13=RP1/RA(13);
Ra14=RP1/RA(14);
%Initializing the array values
k = 1;
l = 1;
i = 12;
for j = 0:5
    %Parallel Formula
    Ra13=1/((1/RB(i))+(1/Ra13));
    RP2=RA(i)*Ra13+Ra13*Ra14+RA(i)*Ra14;
    Ra(k)=RP2/RA(i);
    Ra14=RP2/Ra14;
    Ra13=RP2/Ra13;
    %Iterating the k values
    k = k + 1;
    %Decrmenting the i values
    i = i - 1;
    %Checking whether i=1
    if i == 1
        break;
    end
    Ra13=1/((1/RA(i))+(1/Ra13));
    if i == 3
        w = Ra13;
    end
end

```

```

RP3=RB(i)*Ra13+Ra13*Ra14+RB(i)*Ra14;
Rb(l)=RP3/RB(i);
Ra14=RP3/Ra14;
Ra13=RP3/Ra13;
i = i - 1;
l = l + 1;
end
w1 = w + Ra14;
ans = 0;
for i = 1:k-1
    ans = ans + 1/Ra(i);
end
for i = 1:l-1
    ans = ans +1/Rb(i);
end
%Final Resistance
ans = 1/(ans + 1/w1 + 1/Rb(13))

```

Code 4.1: Finding total impedance

4.3.1. SHORT CIRCUITING DIFFERENT THREADS

The change in impedance is found by short-circuiting the threads at different lengths. Resistance for each cm can be found by dividing the total resistance with the total measure of a single thread used to wave the fabric. Resistance/cm = Total Resistance/3.8.

Firstly 1cm from A1 and B1 are short-circuited and now the resistance is taken from A1 to Ca1 and B1 to Cb1 as shown in Fig. 4.9.

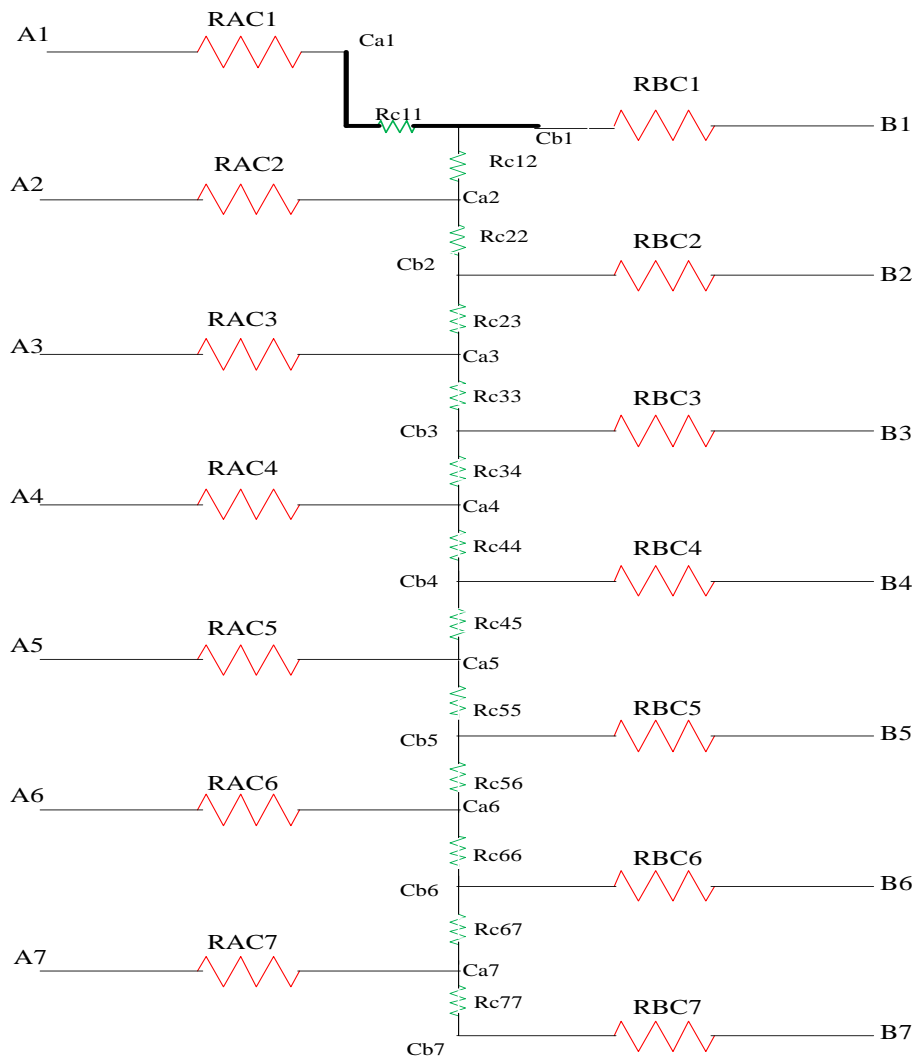

Figure 4.9: Short circuiting the 1st thread for 1cm

Now the impedance is found as calculation done for nominal value before and now the change in impedance is noted. Short-circuiting is then done for 2cm, 3cm and the change in impedance is found. To find more change in impedance the short circuit is done for 2nd thread also for 1cm, 2cm and 3cm and this is also continued for 3rd thread and the impedance is found. Finally the short circuit is done for all the threads for different measurement and the change in impedance is noted.

4.4. ELECTRICAL VALIDATION OF SENSOR CONCEPT

The resistance found for every thread is now checked connecting the resistors in the electronic breadboard. The resistors are connected in the sockets of the breadboard in such a way that it is connected according to the diagram in Fig.4.10. After connecting the resistors the continuity between the sockets is checked in the multimeter. Once the continuity is checked to the the last resistor, the total impedance can be found by keeping the metal pointer in the starting of the resistor and keeping the other metal pointer to the end of the resistor. The short-circuited

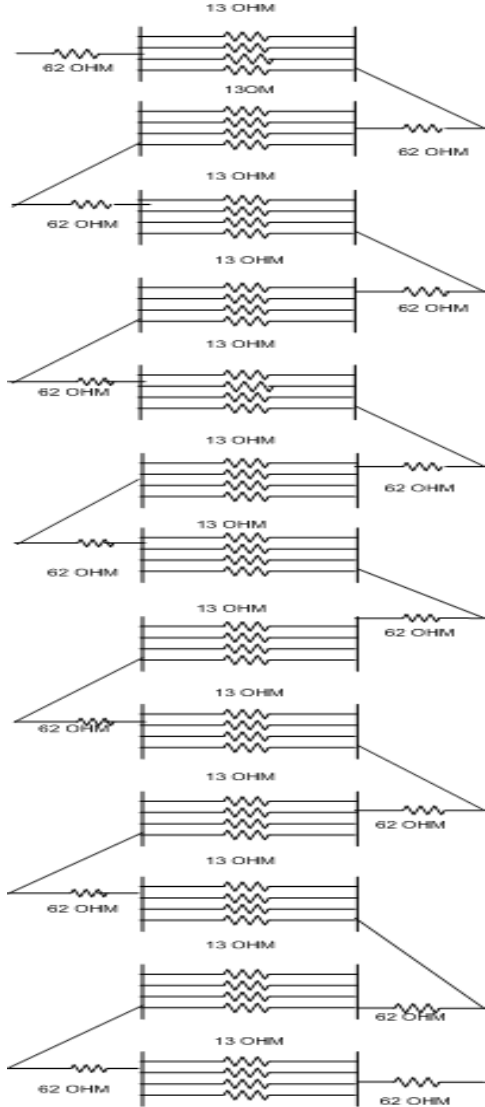

Figure 4.10: Block Diagram of Breadboard

resistance value found in previous chapter is taken as resistors and the impedance for various changes in resistors is found.

4.5. CHARACTERIZATION OF THE MOIST SENSOR

The moist detecting sensor is made by taking a sample of the woven fabric with conductive threads. The conductive fibers weaved as a grid-alike structure in a cotton cloth is taken in such a way that the length of the threads is approximated 3.8cm. Now the sensor is finished by taking all the excess of conductive threads from A part and B part. Both the parts of threads are twinned so that all threads to A and B parts are totally gathered and stripped to the buttons separately. Now the sweat detecting sensor is ready as shown in Fig. 4.11.



Figure 4.11: Sweat detecting sensor

Using a multimeter the nominal impedance can be measured from snap button to snap button. The impedance between any of the buttons and any conductive element of the fabric can be also measured.

4.5.1. SENSOR DYNAMIC CHARACTERIZATION

As discussed earlier the sensor is ready to use. The SFB7 is an impedance spectrometer measurement device manufactured by Impedimed which is the instrument used to measure changes in the impedance at different frequencies. This instrument shows the change instantly for different frequencies and it is stored in the memory. This allows the data to be used at a later time. The change in impedance in the sensor is due to the addition of saline water ($\text{NaCl}9\text{mg/l}$) was measured at DC and at several frequencies. The saline water is dropped in the ends of the threads of the fabric. It creates a wet area with ionic conductivity in between the conductive threads of the fabric and the respective change in impedance is captured, as shown in Fig.5.1. The impedance changes at different frequencies are shown in Fig.5.2.

5.1. RESISTANCE CHARACTERISTICS OF TEXTILE SENSOR

We have taken a textile sensor with the length of 5.6cm forming a pattern as discussed in Chapter 4. The fabric 1.8cm as illustrated in Fig4.1 has several series and parallel connection creating a specific pattern of conductive fibers. When a multimeter is kept at Y interconnections we got the resistance between each pattern for every conductive yarn in 1.8cm and we found 3 Ω for every pattern. When the multimeter is kept at two connectors as in the Fig.4.2 we got the resistance value as follows

	A-3.8cm	B-3.8cm	
A1-Ca1	64 Ω	58 Ω	B1-Cb1
A2-Ca2	72 Ω	55 Ω	B2-Cb2
A3-Ca3	59 Ω	76 Ω	B3-Cb3
A4-Ca4	61 Ω	55 Ω	B4-Cb4
A5-Ca5	54 Ω	84 Ω	B5-Cb5
A6-Ca6	60 Ω	61 Ω	B6-Cb6
A7-Ca7	55 Ω	54 Ω	B7-Cb7

Table 5.1: Resistance between two connectors

A per cm	B per cm
16.85 Ω	15.51 Ω
18.97 Ω	14.53 Ω
15.70 Ω	20.08 Ω
16.18 Ω	14.51 Ω
14.42 Ω	22.26 Ω
15.97 Ω	16.19 Ω
14.48 Ω	14.45 Ω

Table 5.2: Resistance per cm

The obtained resistance value present in Table 5.1 correspond to 3.8cm of conductive yarn, thus dividing it by length provides the resistivity per cm and it is shown in the following Table 5.2.

Thus by theoretical calculation the nominal value for textile sensor is **17.84 Ω** .

The change in impedance is found when the short circuit is done for various measurements. The table below shows impedance values for nominal values for circuiting different threads with different lengths. The values have been obtained by theoretical calculation.

Total Impedance in ohms	Short Circuiting from Ca1 to Cb1 in ohms			Short Circuiting from Ca2 to Cb2 in ohms			Short Circuiting from Ca3 to Cb3 in ohms			Short Circuiting all from Ca to Cb in ohms		
	1cm	2cm	3cm	1cm	2cm	3cm	1cm	2cm	3cm	1cm	2cm	3cm
17.84	17.75	16.86	15.75	16.79	15.24	12.12	16.40	13.81	09.52	14.97	12.45	08.96

Table 5.3: Impedance obtained by calculation

5.2. ELECTRICAL VALIDATION OF TEXTILE SENSOR

The theoretical calculation of the textile sensors is verified by connecting the resistors to the breadboard. Here we have taken 62Ω as the average resistors for A and B part. Instead of taking 3Ω , we took four 13Ω of resistors due to the availability of resistors and it is connected in parallel resulting in 3.5Ω . This electrical validation of the resistor is connected as Fig.4.9. Once the resistors are connected the total impedance is found by keeping one metal pointer at the starting point A and another metal pointer to the ending point B. Thus we got the total impedance as **18.35Ω** . Then as before we short circuit by changing the resistors accordingly we got before.

Total Impedance in ohms	Short Circuiting from Ca1 to Cb1 in ohms			Short Circuiting from Ca2 to Cb2 in ohms		
	1cm	2cm	3cm	1cm	2cm	3cm
18.35	17.85	17.14	15.48	16.93	15.45	11.88

Table 5.4: Impedance obtained by Electrical validation

The below tabular column shows impedance values for nominal values and with short circuiting different threads with different lengths by Electrical Validation.

5.3. RESISTANCE CHARACTERISTICS OF SWEAT SENSOR

As described, a textile sensor made of silver plated conductive fiber weaved in a cotton cloth is used in this project. The conductive fibers are weaved in a grid alike structure. The sensors made are tested with the proposed design by making samples of same length and width that of sample theoretical sensor. When we kept the multimeter between the two connected snap buttons we got the impedance as **18.85Ω** as similar to the theoretical sensor of textile fiber.

We took the resistance value from the 1st snap button to all the threads we got the following measurements

	A-4cm	B-4cm	
A1-Ca1	15.15 Ω	15.65 Ω	B1-Cb1
A2-Ca2	14.62 Ω	14.48 Ω	B2-Cb2
A3-Ca3	14.23 Ω	14.45 Ω	B3-Cb3
A4-Ca4	14.03 Ω	15.48 Ω	B4-Cb4
A5-Ca5	15.53 Ω	15.77 Ω	B5-Cb5
A6-Ca6	15.32 Ω	15.18 Ω	B6-Cb6
A7-Ca7	15.52 Ω	16.87 Ω	B7-Cb7

Table 5.5: Resistance obtained from 1st snap button

We took the resistance value from the 2nd snap button to all the threads, the following measurements were obtained

	A-4cm	B-4cm	
A1-Ca1	17.73 Ω	16.04 Ω	B1-Cb1
A2-Ca2	16.22 Ω	16.02 Ω	B2-Cb2
A3-Ca3	16.58 Ω	14.65 Ω	B3-Cb3
A4-Ca4	16.62 Ω	14.21 Ω	B4-Cb4
A5-Ca5	16.37 Ω	14.50 Ω	B5-Cb5
A6-Ca6	16.59 Ω	14.79 Ω	B6-Cb6
A7-Ca7	15.68 Ω	15.85 Ω	B7-Cb7

Table 5.6: Resistance obtained from 2nd snap button

On the sweat sensor the short-circuit is made by keeping one multimeter in the two snap buttons and another multimeter readings kept in Amps and the pointers are kept in the thread that is made to be short circuited. When the short circuit is done for the first, middle and last thread we got the following measurements.

Total Impedance in ohms	Short Circuiting from Ca1 to Cb1 in ohms			Short Circuiting from Ca4 to Cb4 in ohms			Short Circuiting from Ca7 to Cb7 in ohms		
	1cm	2cm	3cm	1cm	2cm	3cm	1cm	2cm	3cm
18.85	13.70	15.34	15.27	13.66	15.12	15.35	13.61	15.46	15.18

Table 5.7: Resistance obtained for short circuiting different threads of sweat sensor

When the short circuit is done from the first to middle thread and from the middle to last thread we got the readings as follows.

Total Impedance in ohms	Short Circuiting from Ca1 to Cb4 in ohms			Short Circuiting from Ca4 to Cb7 in ohms		
	1cm	2cm	3cm	1cm	2cm	3cm
18.35	17.87	16.34	14.84	16.63	15.45	14.39

Table 5.8: Resistance obtained between various threads of sweat sensor

For testing purposes a solution of saline water was used. The Resistance of the textile sensor with the design proposed in Chapter 4.5, is decreased due to two factors

- * Due to short circuit, when a drop of saline water is poured between two yarns.
- * Due to the fact that resistance of the conductive fiber weaved within the sensor decreases when it come in contact with saline water.

The test, on the sensor, with saline water, showed that the impedance of the sensor did not change much, no matter how much saline water we drop on it. When a drop is added in the sensor of length 3.8cm for frequencies 1k at approx. 70 seconds, it is seen that the impedance decreases from 17.5 Ohms approx. to 16.8 as shown in Fig.5.1. It is due to the creation of wet area with ionic conductivity between the conductive yarns. When the saline is absorbed at 166 seconds from the fabric sensor, conductivity of fabric decreases resulting in the increase in impedance. It is seen from the figure that the value of the impedance returns to the original value.

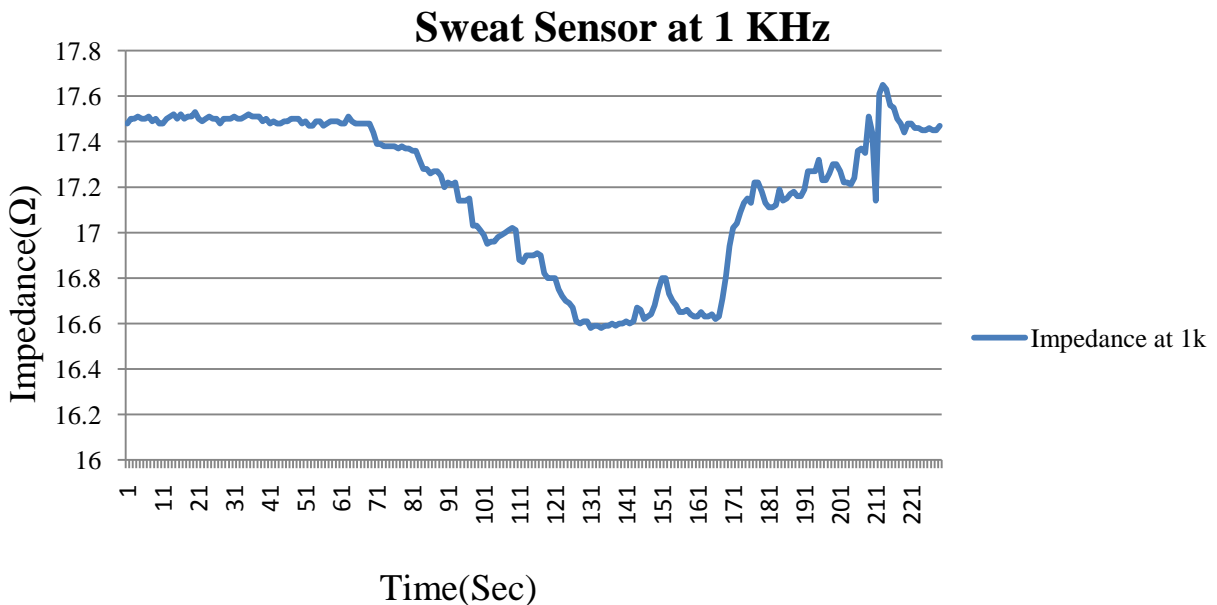

Figure 5.1: Change in impedance at Frequency 1k

When the frequencies are kept in 5k, 10k, 50k and 100k the impedance change is shown in Fig.5.2. It is seen that the impedance changes more when the frequency is high. The behavior is similar at all the frequency measured.

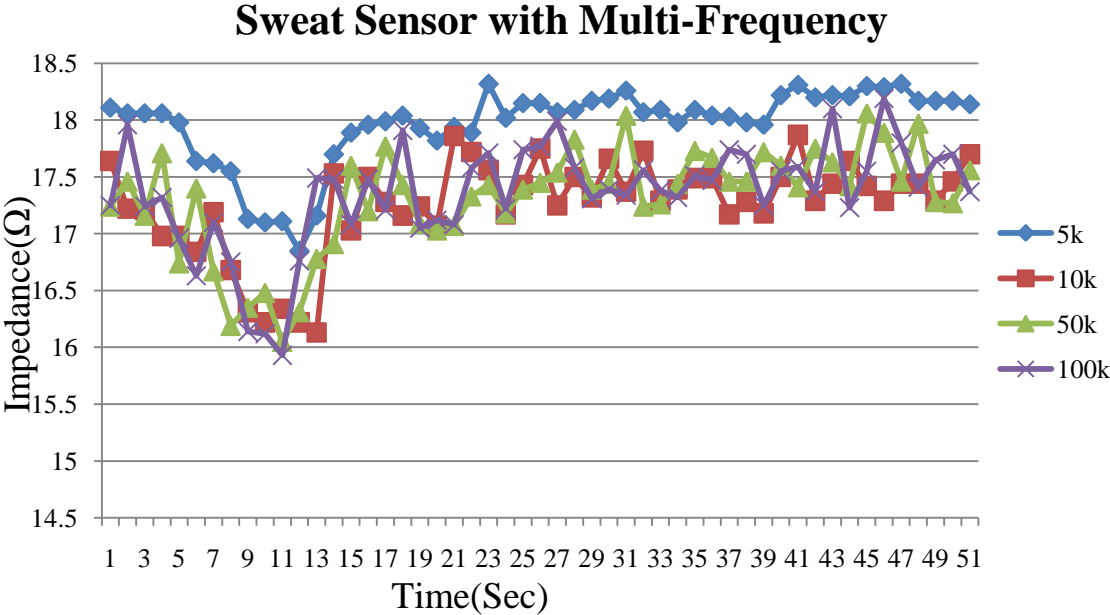

Figure 5.2: Change in impedance for multiple Frequencies

The electrical impedance of the textile sensor and the characterization of the sensor have been done. In this work the fabrics consisting of conductive fibers of specific pattern is used to find the electrical impedance of the confection sensor.

Impedance for the textile sensor measured by multimeter is found by theoretical calculation and electrical validation. Nominal values and short circuit measured at DC are found almost same by both the methods. Short circuit for textile sensor is done for various measurements and impedance changes that are obtained very low.

Sweat detecting sensor works similar to the textile sensor prepared with conductive fiber weaved in specific pattern. Short circuit for various conductive yarns gives changes very low impedance due to the low resistivity. When saline water (NaCl 9mg/l) is added, the sensor detects very small change in impedance due to the resistance of the conductive fiber weaved within the sensor, which makes the resistance to decrease when it comes in contact with saline water.

When the sensor is short circuited the change in impedance is very low which is caused by the mistake of simulating the wet- short circuit as a metallic short circuit instead of ionic. The sensor made works accordingly to the expectations but the implementation cannot be used for detection.

7.1. CONCLUSION

The results obtained for the implemented moisture detection sensor does not show that much change in the impedance when it is been short-circuited or dropping saline water. Although the changes obtained when moistening the sensor are very small, the concept of the sensor itself is valid. The implementation is faulty, not the concept.

The obtained results suggest that the sensor could work if manufactured with a textile fabric of very low conductivity.

7.2. FUTURE WORK

As presented in the results and mentioned in the discussion the changes produced in the impedance of the sensor when being wetted did not produced a large change. In order to obtain a successful textile sensor the following steps are recommended:

- Perform and analysis of the equivalent circuit with larger values of resistivity.
- Perform a short-circuit simulation using high values of resistivity.
- Produce a textile fabric with conductive yarn of low conductivity.
- Perform a deep multifrequency analysis.

References

- [1] K. Gniotek, Z. Stempień, J. Zięba: 'Textronics, a new field of knowledge' (in Polish), *Przegląd Włókienniczy*, no. 2, 2003. 2. K. Gniotek, I. Krucińska: 'The Basic Problem of Textronics', *Fibres & Textiles in Eastern Europe* January/March 2004. Vol. 12 No. 1(45)
- [2] S. Jung, C. Lauterbach, M. Strasser, W. Weber, "Enabling technologies for disappearing electronics in smart textile", *International Conference of SolidState Circuits*, pp. 1-8, February, 2003
- [3] E. Pasquale, F. Lorussi, A. Mazzoldi, D. De Rossi, D., "Strain-sensing fabrics for wearable kinaesthetic-like system", *Sensors Journal, IEEE*, vol. 3, iss. 4, pp. 460-467, August 2003
- [4] Tünde Kirstein, Jose Bonan, Didier Cottet, Gerhard Tröster, "Electronic Textiles for Wearable Computing Systems", *Weareable Computing Lab, ETH Zürich, Switzerland*. 2004
- [5] D. Cottet, J. Grzyb, T. Kirstein, G. Tröster, "Electrical Characterization of Textile Transmission Lines", *IEEE Transactions on Advanced Packaging*, Vol. 26, No. 2, May 2003, pp. 182-190
- [6] Behnem Pourdeyhimi, Edward Grant H. Troy Nagle. "NTC Project: F04-NS17 Printing Electric Circuits onto Non-Woven Conformal Fabrics Using Conductive Inks And Intelligent Control". *National Textile Center Annual Report: November 2004*
- [7] <http://www.imagesco.com/sensors/stretch-sensor.html>
- [8] [http://www.faqs.org/patents/app/20080227349\(temperature\)](http://www.faqs.org/patents/app/20080227349(temperature))
- [9] [http://www.media.mit.edu/resenv/classes/MAS965/readings/TextilePressureSensor.pdf\(pressure\)](http://www.media.mit.edu/resenv/classes/MAS965/readings/TextilePressureSensor.pdf(pressure))
- [10] L. Rattfält, *et al.*, "Electrical characteristics of conductive yarns and textile electrodes for medical applications," *Medical and Biological Engineering and Computing*, vol. 45, pp. 1251-1257, 2007
- [11] http://smart2.qred.fi/files/myontec/media/Physiological_Measurement_article.pdf
- [12] [http://www.myontec.com/media/conferenceEMG300605.pdf.\(textile electrode\)](http://www.myontec.com/media/conferenceEMG300605.pdf.(textile%20electrode))
- [13] Numetrex. (2006, 19 July). *NuMetrex Heart Sensing Sports Bra*. Available: <http://www.numetrex.com/company/press-room>
- [14] [http://www.springerlink.com/content/ux4t481p49247j41/\(chemical sensors\)](http://www.springerlink.com/content/ux4t481p49247j41/(chemical%20sensors))
- [15] [http://www.gizmag.com/smart-underwear/15492/\(chemical sensors\)](http://www.gizmag.com/smart-underwear/15492/(chemical%20sensors))
- [16] [http://www.heidelberger-innovationsforum.de/fileadmin/heidelberger/downloads/Praesentationen_April08/15_Rumpf.pdf\(moisture sensors\)](http://www.heidelberger-innovationsforum.de/fileadmin/heidelberger/downloads/Praesentationen_April08/15_Rumpf.pdf(moisture%20sensors))
- [17] http://en.wikipedia.org/wiki/Electrical_impedance#Measurement
- [18] <http://encyclopedia2.thefreedictionary.com/Electrical+resistance>
- [19] <http://en.wikipedia.org/wiki/Ohm>
- [20] <http://en.wikipedia.org/wiki/Multimeter>
- [21] http://en.wikipedia.org/wiki/Electrical_resistance